

CAVO MOTORE CAVO ALIMENTAZIONE

ALIMENTAZIONE:CAVO H07RNF 4G1,5mmq  
LUNGHEZZA 10 mt. TOTALI

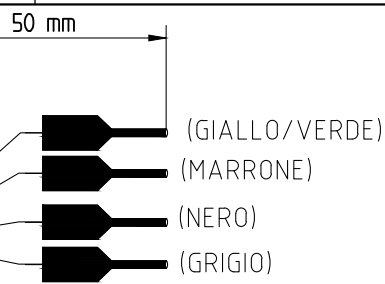

# CASSETTA GRIGIA MANIGLIA ROSSA

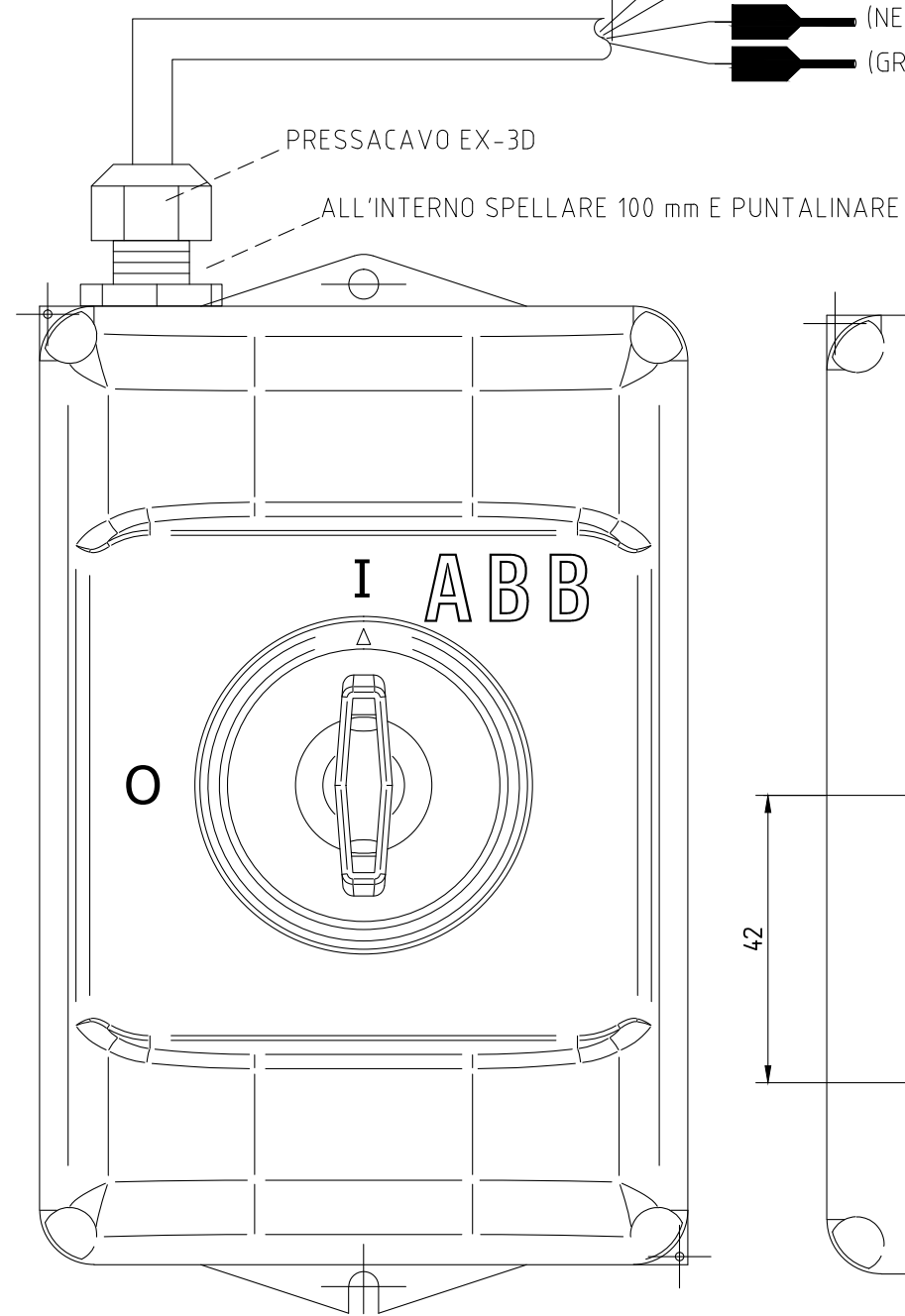
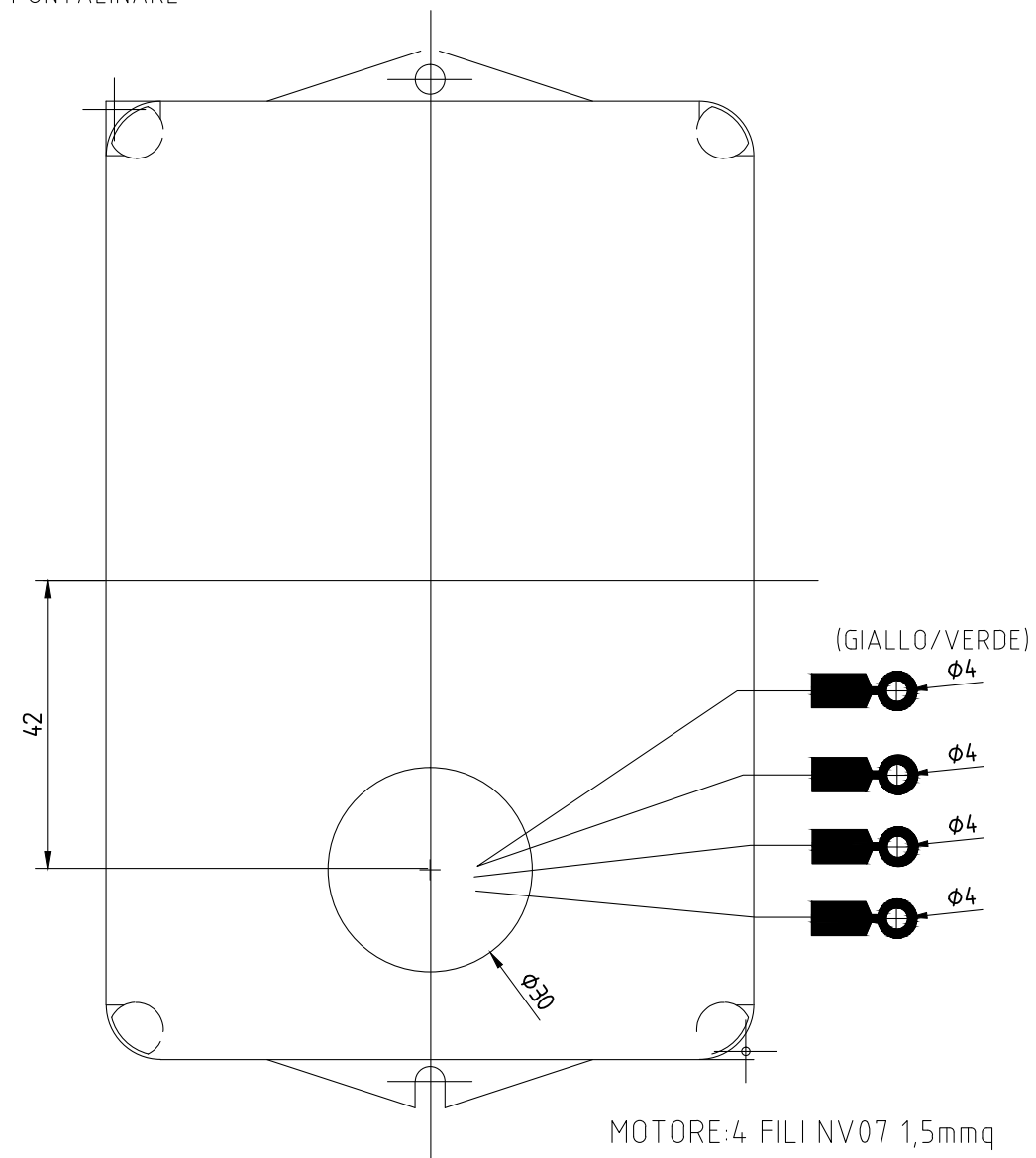

MOTORE:4 FILI NV07 1,5mmq  
LUNGHEZZA 170 mm. TOTALI

MATERIALE	COLORE	FINITURA	TRATTAMENTO TERMICO	TIPO DI PRODOTTO
APICE	MODIFICHE	NOME	DATA	
TOLLERANZE se non diversamente specificato: fino a 6 ± 0.1 / da 6 a 30 ± 0.2 da 30 a 120 ± 0.3 da 120 a 315 ± 0.5/ da 315 a 1000 ± 0.8/ da 1000 a 2000 ± 1.2/ da 2000 a 4000 ± 2		DENOMINAZIONE		SCALA
APPROVATO	DATA			DISEGNATO
				COD. GHIBLI
				COD.